



**PRODUCT GUIDE**  
**- WC DGAB GEAR OPERATOR SERIES -**



**EXPECT QUALITY AND RELIABILITY**

**using our brand name WC DGAB GEAR OPERATOR SERIES**

Version 3.0

**Head Office:**



7596 Wagner RD NW  
Edmonton , Alberta CANADA T6E 5B2  
[info@weirusa.com](mailto:info@weirusa.com) / [www.weirusa.com](http://www.weirusa.com)

1.866.462.1910 Toll Free  
780.462.1910 ph | 780.462.1959 fax



**DOMESTIC PRODUCTS MADE IN NORTH AMERICA**  
**Details are the difference between ordinary and EXCELLENCE**



## GEAR OPERATOR FEATURES

Suitable for connections to Butterfly valve, Ball valve, and Plug valve.

### SOLID AND CLEAN DESIGN

Weatherproof housing, manufactured from high strength WCB steel protects and isolates internal operating parts from dirt and water. Larger units utilize oil seals at bottom of gear hub.

### DESIGNED TO FIT 90° ROTATION

Butterfly, plug or ball valves, and other equipment such as dampers. Outputs up to 50,000 inch pounds of torque.

### DURABLE

Comes standard with ductile iron worm segments. Optional Aluminum Bronze worm segments also available.

### ADJUSTABLE

Screws allow a  $\pm 5^\circ$  range at end of travel.

### EASY MOUNTING

Customers can specify location, size, and number of tapped mounting holes as well as bore and keyway dimensions. For specific applications, adaptor plates or flanged base operators may be employed

# Weir USA at work for you

## WC DGAB SERIES PARTS ORDERING

Please specify the following:

- Model number of valve to connect to
- Required torque
- Mounting hole pattern and thread size (optional)
- Input shaft roll pin hole or keyway size (optional)

**CUSTOM HARDWARE AVAILABLE TO MOUNT TO ANY APPLICATION**  
**WELDED STEEL HANDWHEELS AVAILABLE**  
**IN SIZE RANGES FROM 10" TO 30"**

MATERIAL TABLE		
Description	Qty.	Material
1. Housing	1	ASTM 216WCB
2. Cover	2	ASTM 216WCB
3. Worm	1	ASTM 216WCB
4. Bearing Seat	2	ASTM A29 1045
5. Handwheel	1	45
6. Cover	1	HT200
7. Worm Gear	1	QT450
8. Segment	1	Q235

WEIGHT LIST	
Description	Material
<b>WC-DGAB24-F10</b>	<b>10 LBS.</b>
<b>WC-DGAB36-F12</b>	<b>16 LBS.</b>
<b>WC-DGAB41-F14</b>	<b>25 LBS.</b>
<b>WC-DGAB68-F16</b>	<b>53 LBS.</b>
<b>WC-DGAB178-F16</b>	<b>76 LBS.</b>



MODEL INFORMATION		
Model	Gear Ratio	Torque IN-LBS.
WC DGAB24	24-1	3540
WC DGAB36	36-1	6637.5
WC DGAB41	41-1	11505
WCDGAB68	68-1	26550
WCDGAB178	178-1	60180

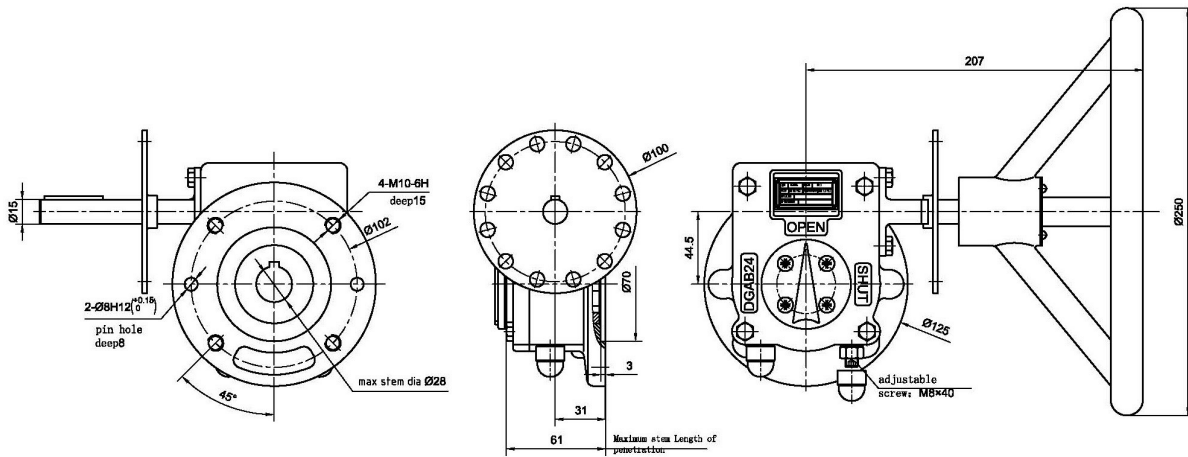

output flange:F10	ratio: 24:1	
No: AD07-01	rated input torque: 56 N.m	
design:	max output torque:400 N.m	worm gearbox
date: 2020-4-7	Torque amplification factor (±10%): 7.2	
		DGAB24-F10A

Part Number: WC-DGAB36

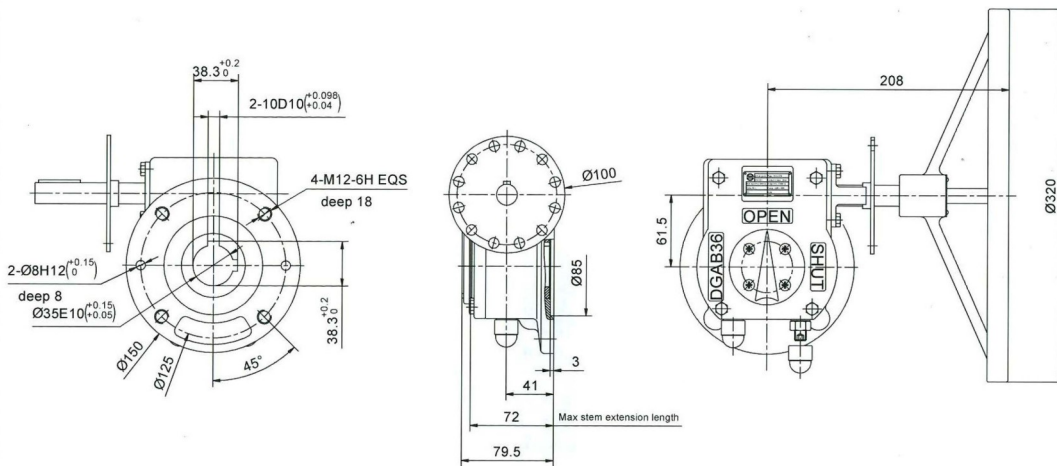

Output Flange:F12	Transmission Ratio	36:1
NO: AC12-01	Max Input Torque	68 N.m
Designer:	Output Torque	750 N.m
Date: 12/3-2020	Mechanical Adv. (±10%)	11

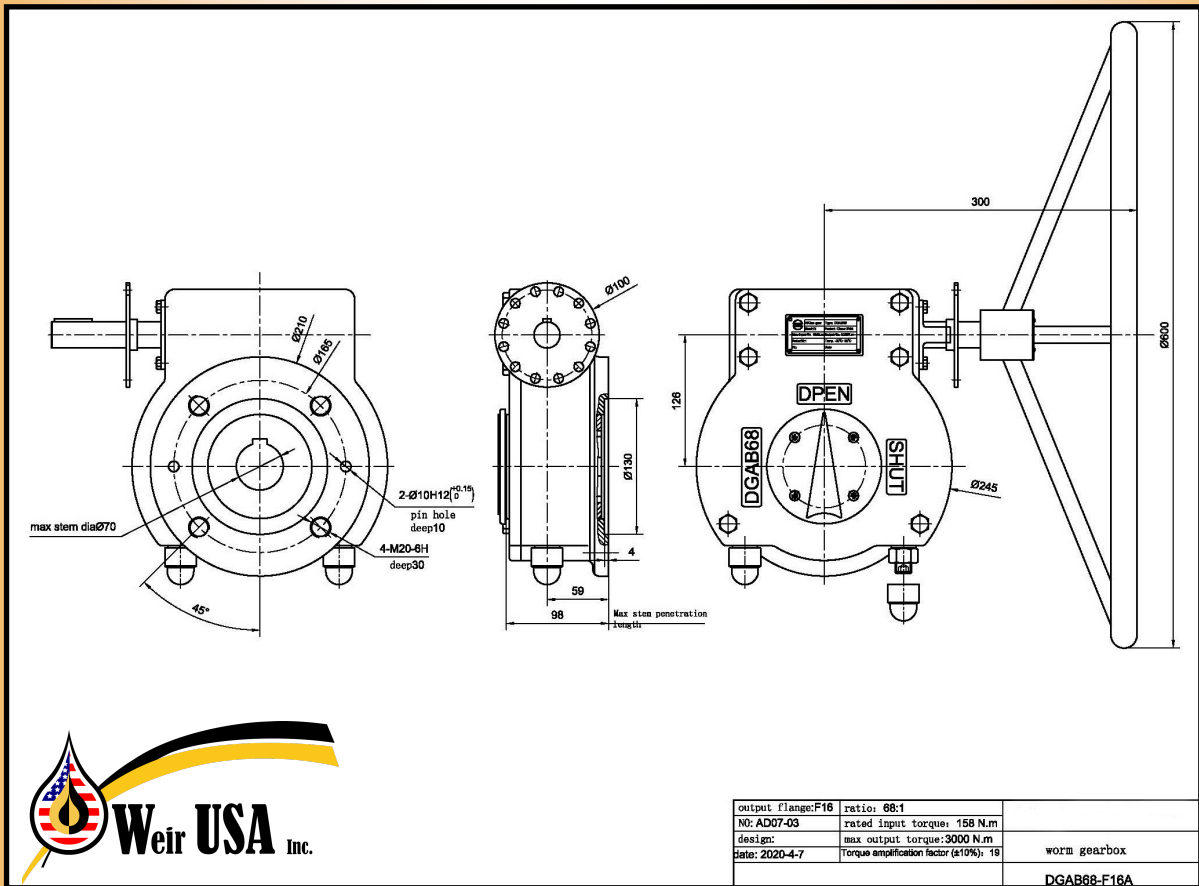
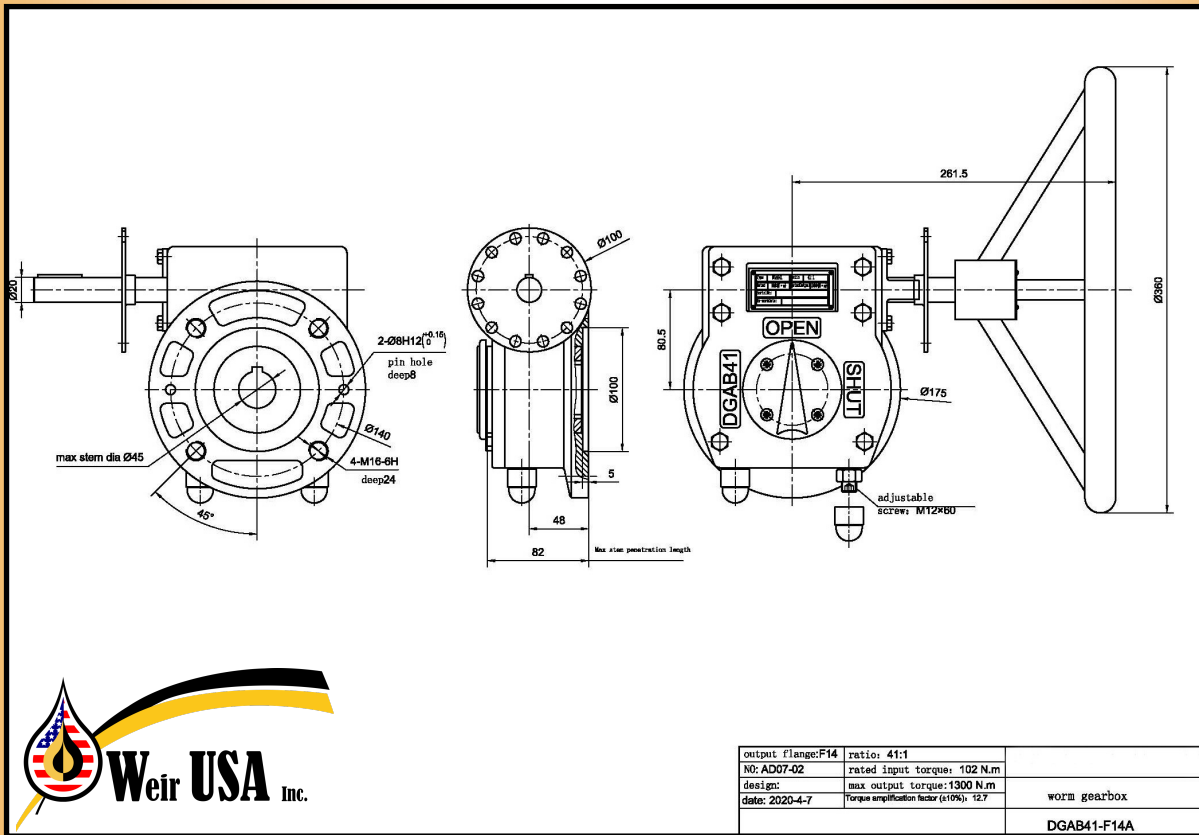

# PRODUCT GUIDE

## WEIR WC DGAB GEAR OPERATOR SERIES

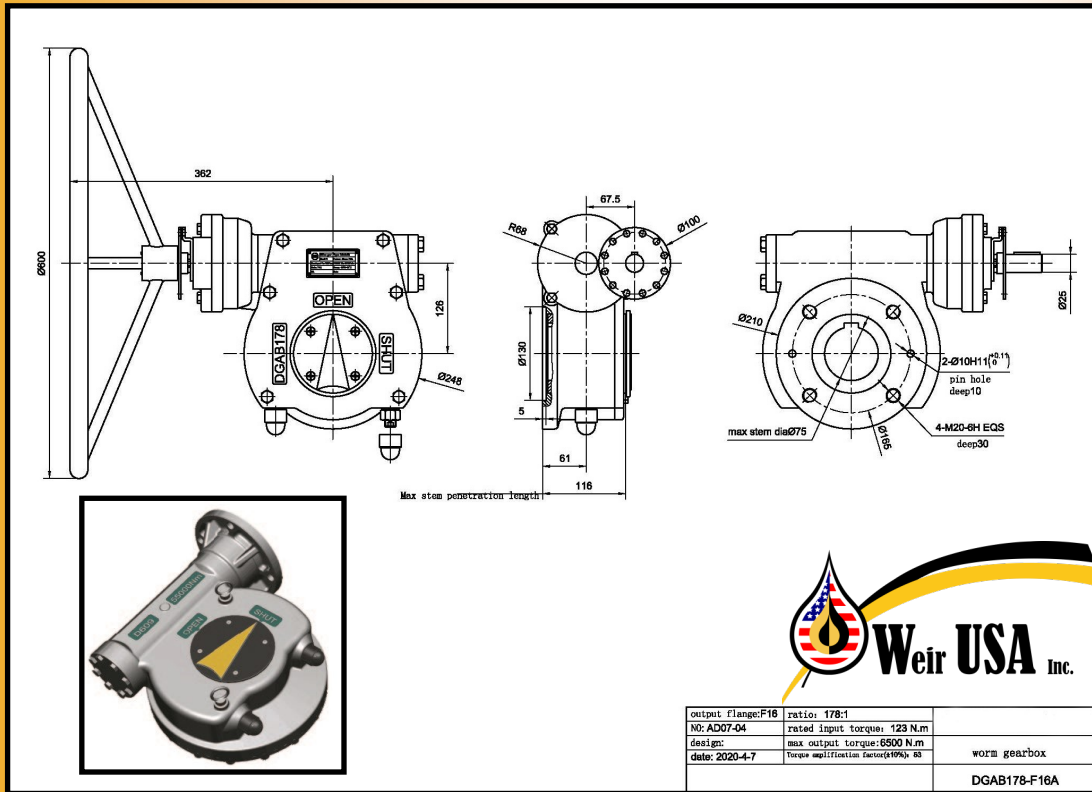

**SOLUTIONS FOR YOUR COMPANY NEEDS - WORLD WIDE SHIPPING**



**- HELP DESK -**

FOR YOUR SUPPORT AND SERVICE

**24 hours a day, 7 days a week**

**NO CHARGE ON CALLS SERVICE**

We offer technical assistance, product knowledge, and reliable trouble shooting

Brochures/Maintenance info available online [www.weirusa.com](http://www.weirusa.com)



**Head Office:**

7596 Wagner RD NW

Edmonton, Alberta CANADA T6E 5B2

[info@weirusa.com](mailto:info@weirusa.com) / [www.weirusa.com](http://www.weirusa.com)

1.866.462.1910 Toll Free

780.462.1910 ph | 780.462.1959 fax