



PRODUCT GUIDE
WCM HYDRAULIC ACTUATORS SERIES
- WCM35 / WCM50 / WCM60 / WCM70 -



EXPECT QUALITY AND RELIABILITY
using our brand name HYDRAULIC ACTUATORS

~ WARRANTY AND EXCHANGE PROGRAM ~

Version 3.0

Head Office:



7596 Wagner RD NW
Edmonton , Alberta CANADA T6E 5B2
info@weirusa.com / www.weirusa.com

1.866.462.1910 Toll Free
780.462.1910 ph | 780.462.1959 fax



Weir USA Inc.

DOMESTIC PRODUCTS MADE IN NORTH AMERICA
Details are the difference between ordinary and EXCELLENCE



Each WCM Hydraulic Actuator Series Actuator is frozen and tested for a **MINIMUM of 24 HOURS**



Solutions for your company needs

CUSTOM DESIGN AND MANUFACTURING AVAILABLE

STANDARD Range -50°C to 150°C

FEATURES - Design Construction

- Scotch yoke mechanism for high breakaway and reseat torque, ideal for quarter turn valves.
- Modular with basic drive case/cylinder combinations to suit most economically field requirements.
- O-Ring pistol type for reliable, positive sealing.
- Double acting for spring return styles.
- Stabilized drive rods where required by side loads.
- Safe, reliable, and field removable spring cartridges.
- Tie rod cylinder construction for simplified maintenance.
- SST pressure cylinder for corrosion resistance.

Weir offers technical consulting and provides a total end to end solution.

Material

- Durable, lightweight cast aluminum drive cases are standard, ideal for low temperature.
- Ductile iron yokes or stress relieved cast steel drive cases available.
- Filament wound fibreglass pneumatic cylinders (steel cylinders optional); steel hydraulic cylinders.
- LTN seals are standard; special low temperature or fluoroelastomer seals are also available.
- No brass or bronze components.
- Special trims and coating for corrosive applications.

QUALITY AND PERFORMANCE TESTED

PNEUMATIC OPERATORS

MODEL IDENTIFICATION

Cylinder Size	Series Number	Cylinders	Model Suffixes (Omitted if Not Applicable)			
OO Cylinder Bore Diameter	OO Identifies Series	X Cylinder Arrangement	SR Spring Return Model	OOO Spring Class	Hydraulic	MXX Manual Override Options
Omitted here because each cylinder has a unique cylinder bore diameter from 3/8" to 7" diameter.	35 50 60 70	"S" for one or "D" for two cylinders pressurized per stroke. DSRH models are exceptions. They use one single acting hydraulic cylinder opposite the designated spring.	A spring provides for "fail safe" operation. Spring Class identifies particular spring.	Hydraulic model	"MJ" - single jackscrew and handwheel "MJJ" - Dual jackscrew and handwheel.	

WEIR HYDRAULIC ACTUATOR SERIES OPERATES IN TANDUM AS AN **EMERGENCY SHUTDOWN SYSTEM**

WITH OUR WCSCHP*

*Weir Self Contained High Pressure Pump

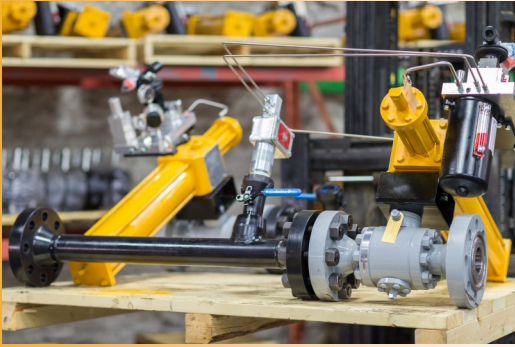

WCM35&50 DIMENSIONS AND DATA - PNEUMATIC OPERATORS

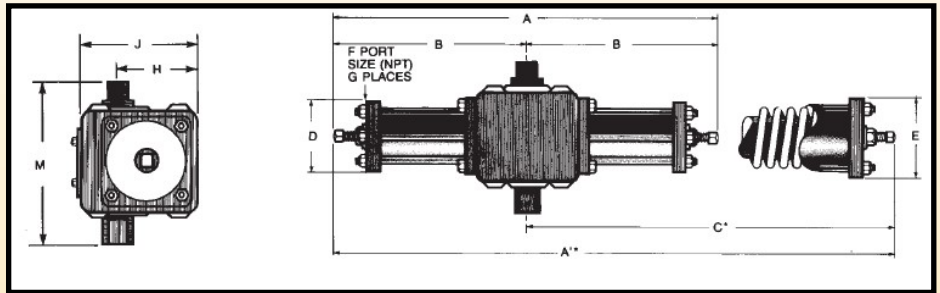

MOUNTING CONTROLS

- Low temperature trim is standard: -58 to 302F (LT Buna)
- High temperature is optional: -4 to 392F (H-T Fluoroelastomer/Steel)
- 4 to 437F (H-T Fluoroelastmer/Steel)

Extreme low temperature is optional: -85 to 302F (Fsi/Polyslide)

CUSTOM DESIGN AND MANUFACTURING AVAILABLE

MODEL	Dimensions (in)											Weight (lb.)	Actuator Displacement (in ³)	Nominal Stroke (in)	Cylinder Bore (in)
	A	A*	B	C*	D	E	F	G	H	J	M				
35 SH	21	-	10-1/2	-	3-1/4	-	1/4	2	4-1/4	6	7-3/8	25	5.7	2-3/4	1-5/8
35 DSRH	-	31-3/4	10-3/8	21-3/8	3-1/4	4-1/4	1/4	1	4-1/4	6	7-3/8	40	5.7	2-3/4	1-5/8
50 SH	30	-	15	-	5	-	1/4	2	5-3/8	7-1/2	10-5/8	70	22.1	4-1/2	2-1/2
50 DSRH	-	48-1/2	16	32-1/2	5	6	1/4	1	5-3/8	7-1/2	10-5/8	90	22.1	4-1/2	2-1/2
60 SH	34	-	17	-	5-1/2	-	1/4	2	6-1/2	9-3/8	12-9/16	90	38.9	5-1/2	3
60 DSRH	-	54	18	36	5-1/2	7	1/4	1	6-1/2	9-3/8	12-9/16	150	38.9	5-1/2	3
70 SH	40	-	20	-	5-5/8	-	1/4	2	7-3/4	11	14-1/2	140	64.9	6-3/4	3-1/2
70 DSRH	-	65-3/4	21	44-3/4	5-5/8	8-1/4	1/4	1	7-3/4	11	14-1/2	260	64.9	6-3/4	3-1/2

*Note: Dimensions A and C refer to spring return models.

**DOMESTIC PRODUCTS
MADE IN
NORTH AMERICA**



WEIR HYDRAULIC ACTUATOR SERIES
OPERATES IN TANDUM AS AN
EMERGENCY SHUTDOWN SYSTEM

WITH OUR WCSCHP*

*Weir Self Contained High Pressure Pump



MOUNTING CONTROLS

- Low temperature trim is standard:
-58 to 302F (LT Buna)
- High temperature is optional:
-4 to 392F (H-T Fluoroelastomer/Steel)
-4 to 437F (H-T Fluoroelastomer/Steel)

Extreme low temperature is optional:

-85 to 302F (Fsi/Polyslide)

NOTE: SPRING RETURN OPERATORS

Calculated torques based on efficiency of 80%, as applied to spring force and piston force.

Higher pressures may be available - consult Weir for technical service.

HYDRAULIC OPERATORS AND SPRING RETURN OPERATORS

WCM HYDRAULIC ACTUATOR SERIES DIMENSIONS AND DATA

Model	Max. Oper. Pressure (PSIG)	750PSIG	1000PSIG
35SH	2000	3240	4560
50SH	2000	13300	17700
60SH	2000	23200	31000
70SH	2000	39000	52000
23SH	1500	13500	18000
33DH	1500	48700	65000
43DH	1500	97500	130,000
53DH	1440	112,000	150,000
46DH	1500	115,000	153,000
56DH	1500	205,000	273,000
66DH	1500	315,000	400,000
57DH	1500	238,000	317,000
67DH	1500	392,000	523,000
77DH	1500	574,000	766,000
87DH	1500	780,000	1,040,000
97DH	1500	1,020,000	1,360,000
107DH	1440	1,290,000	1,500,000
107DH-9B	1440	1,500,000	1,500,000

Note: all torques in lb.in. - minimum torque is 1/2 end

SPRING RETURN OPERATORS

						cal. hyd. loading torque at min operating pressure (lb.in)*		
35DSR								
M-100	200	275	2730	1060	1530	2710	1050	1500
50DSR								
H-100	800	2000**	9770	3870	5700	8440	3200	4370
60DSR								
H-100	1000	2000**	16300	6400	9420	12200	4630	5280
70DSR								
H-100	800	2000**	27700	10900	15800	25800	9910	13800

*Note: Calculated torques based on efficiency of 80%, as applied to spring force and piston force.

WEIR HYDRAULIC ACTUATOR SERIES
OPERATES IN TANDUM AS AN
EMERGENCY SHUTDOWN SYSTEM
WITH OUR WCSCHP*

*Weir Self Contained High Pressure Pump



MOUNTING AND DRIVECASE DIMENSIONS

MOUNTING CONTROLS

- Low temperature trim is standard:
-58 to 302F (LT Buna)
- High temperature is optional:
-4 to 392F (H-T Fluoroelastomer/Steel)
-4 to 437F (H-T Fluoroelastomer/Steel)

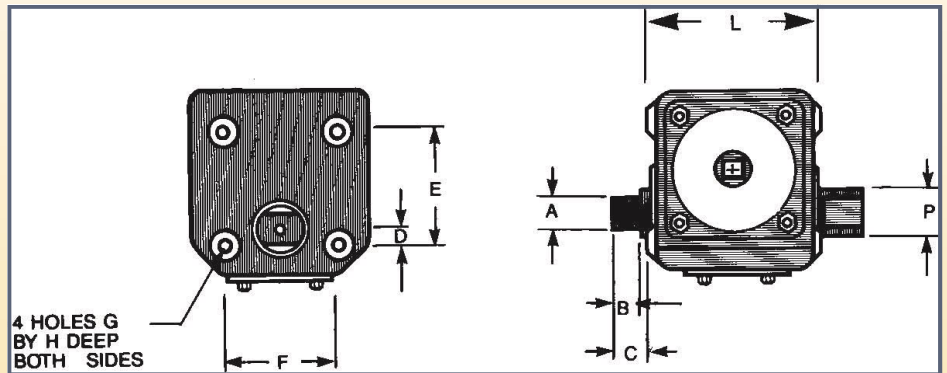

Operator Series	Dimensions (in)									
	A	B	C	D	E	F	G	H	P	L
35	7/8	1	1-3/8	7/8	4-1/4	3	3/8-16NC	1-1/4	1-1/4	4-5/8
50	1-1/2	1-1/4	2	1/2	4	5	1/2-13NC	1-1/2	2	4-5/8
60	1-3/4	1-3/4	1-1/4	1/2	5-3/8	5-3/4	5/8-11NC	1	2-1/4	8-1/16
70	2	2	2-1/2	1/2	6	7	3/4-10NC	1-1/4	2-1/2	9-1/2

**DOMESTIC PRODUCTS
MADE IN
NORTH AMERICA**



**WEIR HYDRAULIC ACTUATOR SERIES OPERATES IN TANDUM AS AN
EMERGENCY SHUTDOWN SYSTEM WITH OUR WCSCHP***

*Weir Self Contained High Pressure Pump

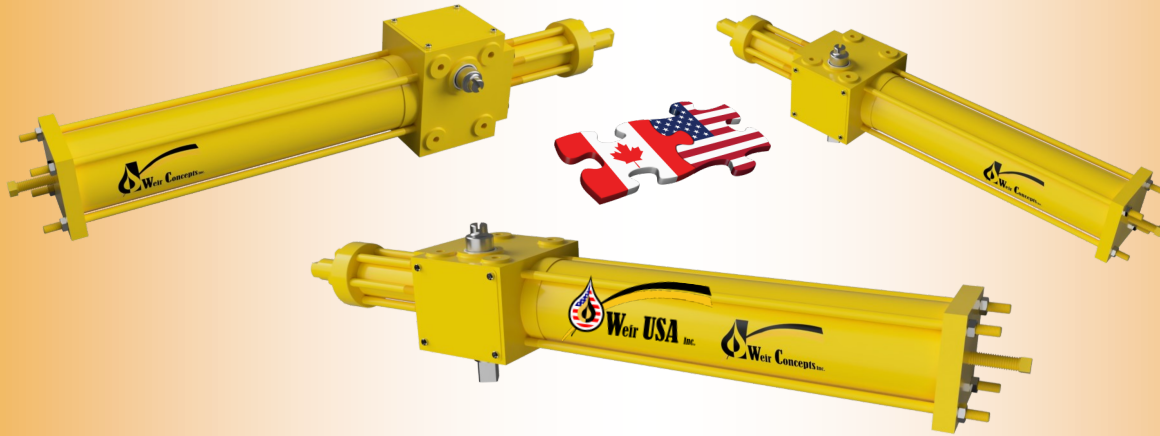

MOUNTING CONTROLS

- Low temperature trim is standard:
-58 to 302F (LT Buna)
- High temperature is optional:
-4 to 392F (H-T Fluoroelastmer/Steel)
-4 to 437F (H-T Fluoroelastmer/Steel)

Extreme low temperature is optional:

-85 to 302F (Fsi/Polyslide)

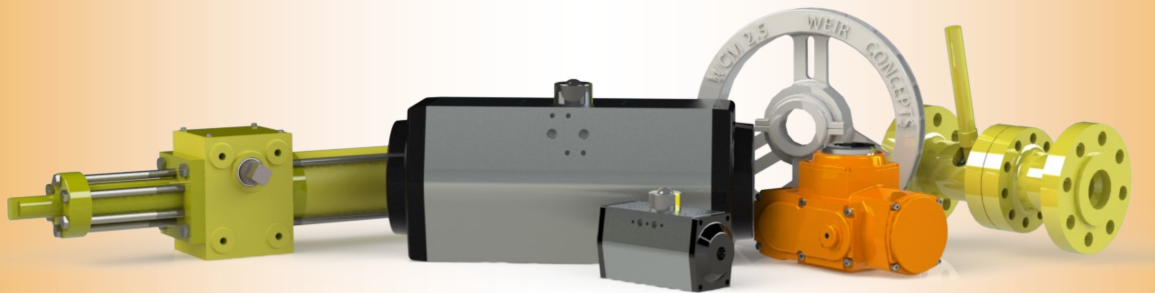

ASK US ABOUT OUR OTHER PRODUCTS LINES

Weir WCM35

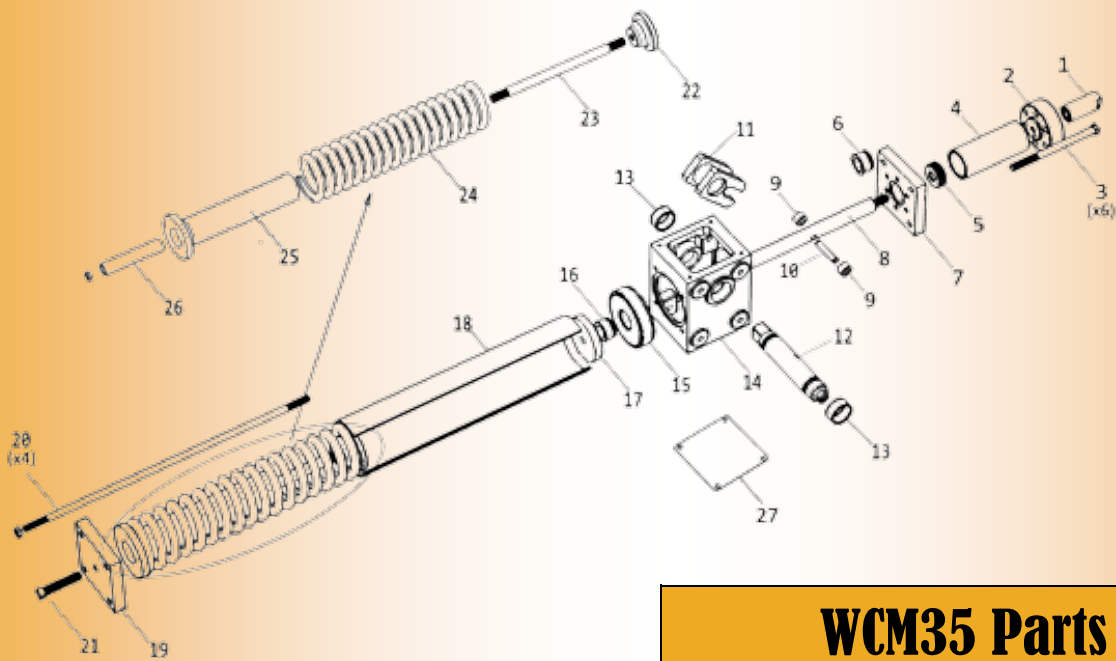

WCM35 Parts List

WCM35001	Travel Stop Cover
WCM35002	High Pressure End Cap
WCM35004	High Pressure Cylinder
WCM35005	High Pressure Piston
WCM35006	Spring Plate Bushing
WCM35007	High Pressure End Plate
WCM35008	Piston Rod
WCM35009	Piston Rod Pin Bearing
WCM35010	Drive Rod Pin
WCM35011	Drive Yolk
WCM35012	Drive Shaft
WCM35013	Body Bushing
WCM35014	Body
WCM35015	Spring Body Plate
WCM35016	Spring Plate
WCM35017	Spring Tube
WCM35018	Spring End Cap
WCM35019	Spring Cartridge Stud
WCM35021	Spring Stop Washer
WCM35022	Spring Preload Seat
WCM35023	Spring Preload Stud
WCM35024	Spring - 100
WCM35025	Spring Preload Barrel
WCM35026	Spring Spacer Tube

Weir WCM50

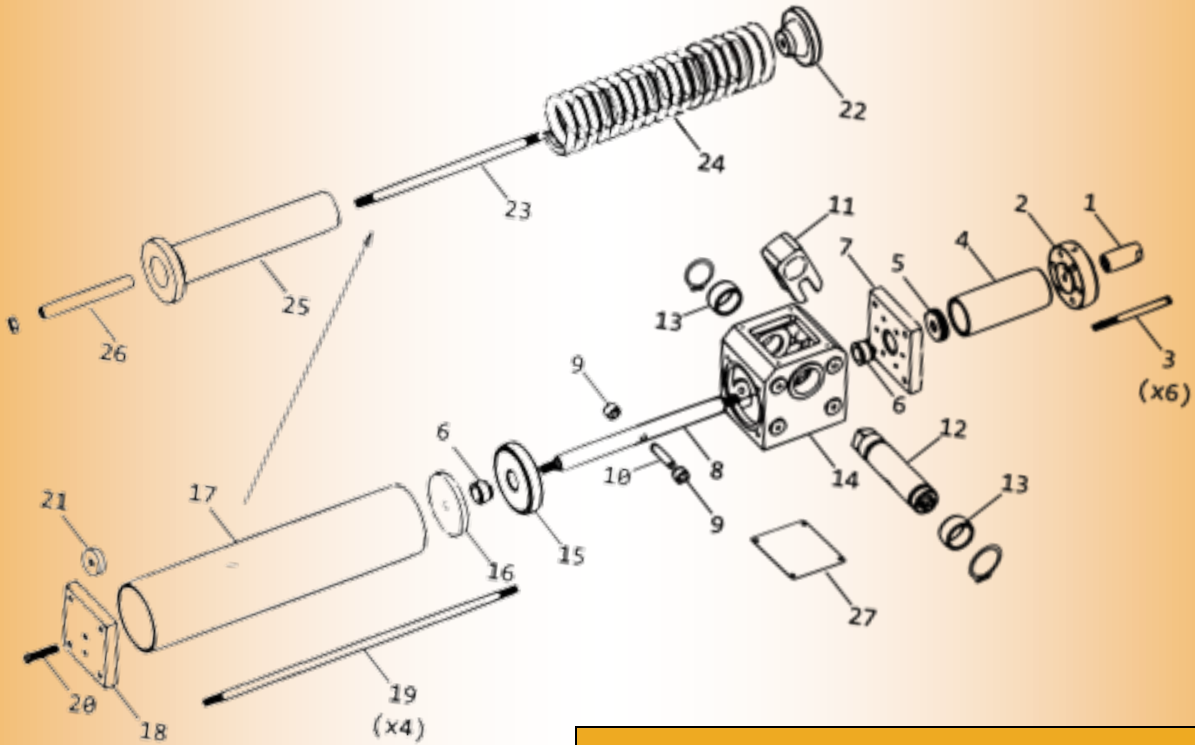

WCM50 Parts List

WCM50001	Travel Stop Cover
WCM50002	High Pressure End Cap
WCM50004	High Pressure Cylinder
WCM50005	High Pressure Piston
WCM50006	Piston Rod Bearing
WCM50007	High Pressure End Plate
WCM50008	Piston Rod
WCM50009	Piston Rod Pin Bearing
WCM50010	Piston Rod Pin
WCM50011	Drive Yolk
WCM50012	Drive Shaft
WCM50013	Body Bushing
WCM50014	Body
WCM50015	Body Plate
WCM50016	Spring Plate
WCM50017	Spring Tube
WCM50018	Spring End Cap
WCM50019	Spring Cartridge Stud
WCM50021	Spring Stop Washer
WCM50022	Spring Preload Seat
WCM50023	Spring Preload Stud
WCM50024	Spring - 100
WCM50025	Spring Preload Barrel
WCM50026	Spring Spacer Tube

*Note: WCSCHP - Weir Self Contained High Pressure Pump

Weir WCM60

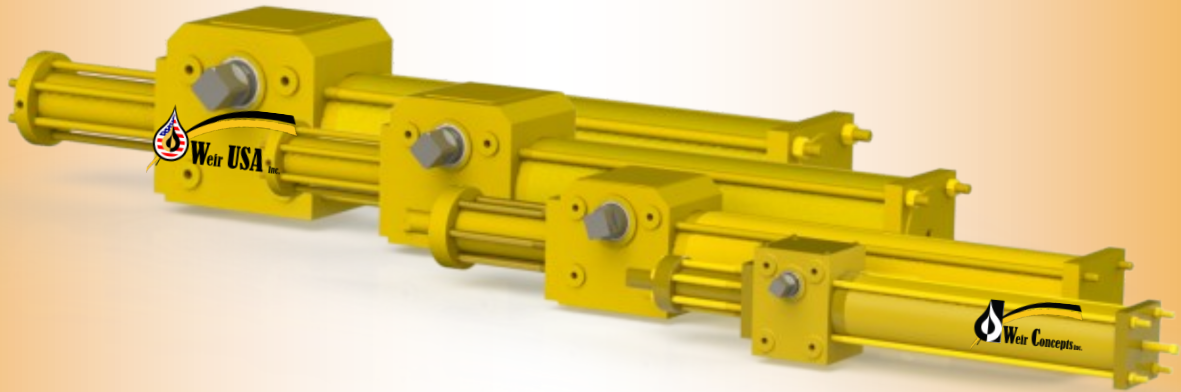

WCM60 Hydraulic Actuator Assembly

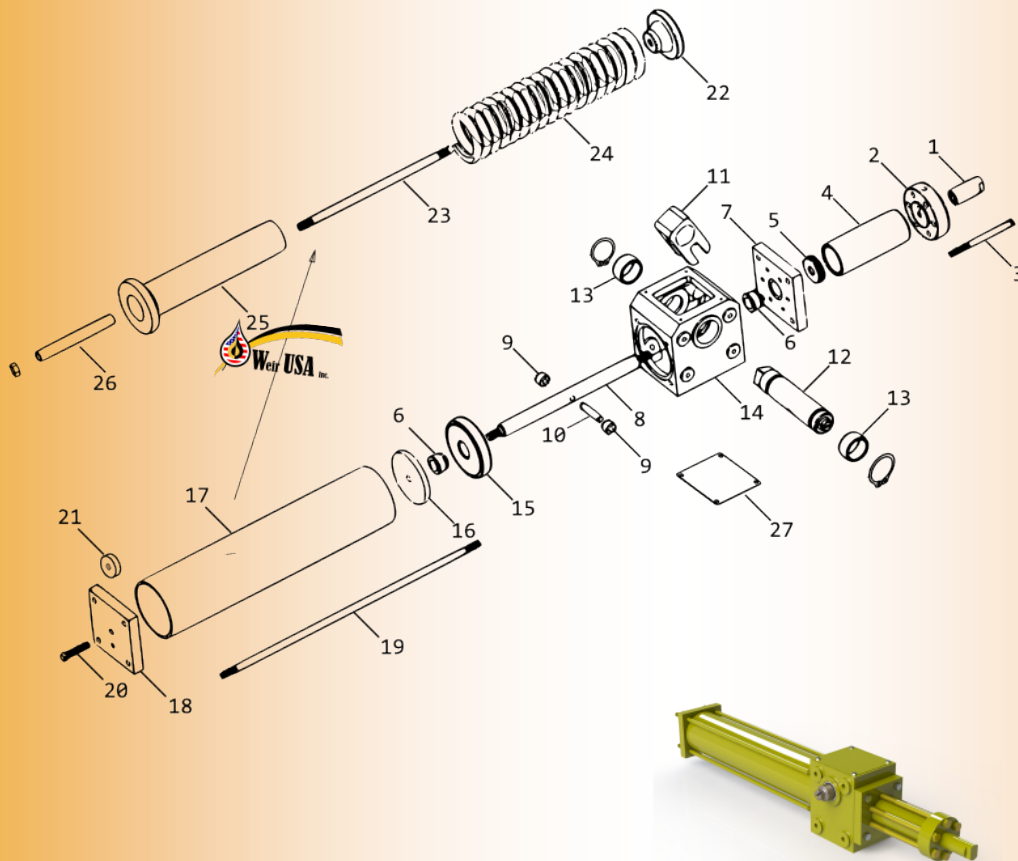

- WCM60001 - Travel Stop Cover
- WCM60002 - High Pressure End Cap
- WCM60003 - High Pressure Bolt
- WCM60004 - High Pressure Cylinder
- WCM60005 - High Pressure Piston
- WCM60006 - Piston Rod Plate Bushing
- WCM60006 - Spring Plate Bushing
- WCM60007 - High Pressure Body Plate
- WCM60008 - Piston Rod
- WCM60009 - Piston Rod Pin Bearing
- WCM60010 - Piston Rod Pin
- WCM60011 - Drive Yolk
- WCM60012 - Drive Shaft
- WCM60013 - Body Bushing
- WCM60014 - Body
- WCM60015 - Spring Body Plate
- WCM60016 - Spring Plate
- WCM60017 - Spring Tube
- WCM60018 - Spring End Cap
- WCM60019 - Spring Cartridge Stud
- WCM60020 - Spring Set Screw
- WCM60021 - Spring Stop Washer
- WCM60022 - Spring Preload Seat
- WCM60023 - Spring Preload Stud
- WCM60024 - Spring-100
- WCM60025 - Spring Preload Barrel
- WCM60026 - Spring Spacer Tube
- WCM60027 - Name Plate

*Note: WCSCHP - Weir Self Contained High Pressure Pump

Weir WCM70

WCM70 Hydraulic Actuator Assembly

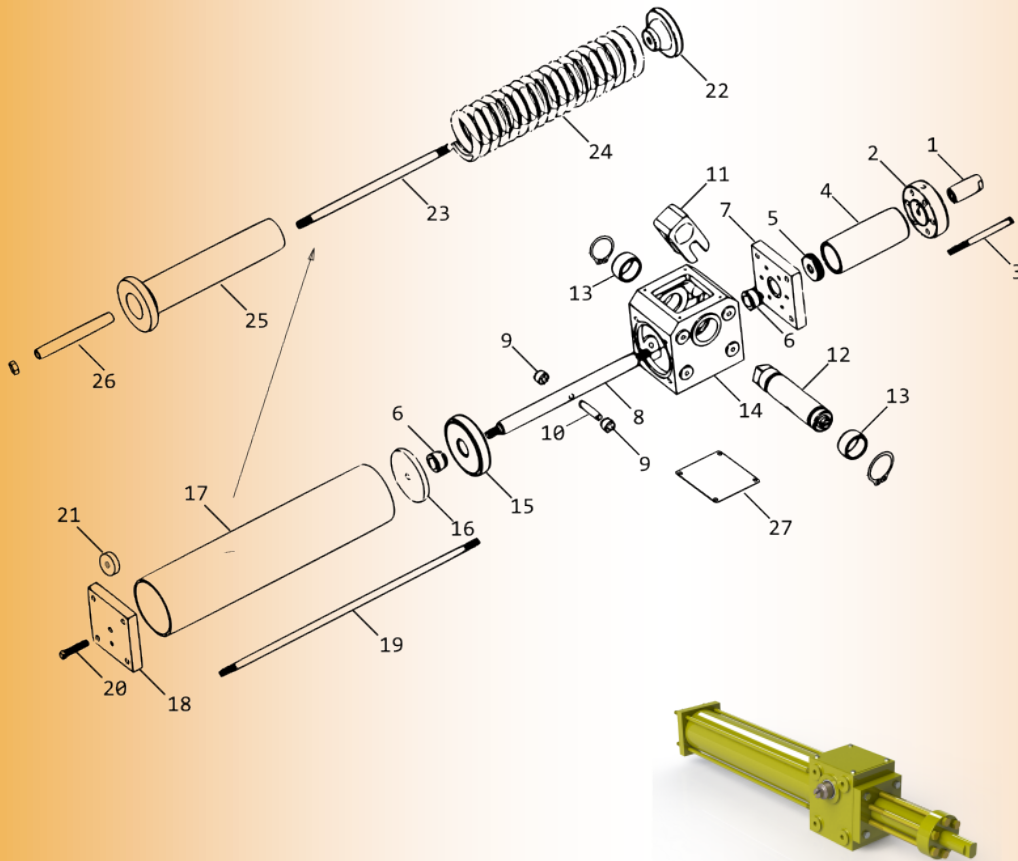

- WCM70001 - Travel Stop Cover
- WCM70002 - High Pressure End Cap
- WCM70003 - High Pressure Bolt
- WCM70004 - High Pressure Cylinder
- WCM70005 - High Pressure Piston
- WCM70006 - Piston Rod Plate Bushing
- WCM70006 - Spring Plate Bushing
- WCM70007 - High Pressure Body Plate
- WCM70008 - Piston Rod
- WCM70009 - Piston Rod Pin Bearing
- WCM70010 - Piston Rod Pin
- WCM70011 - Drive Yolk
- WCM70012 - Drive Shaft
- WCM70013 - Body Bushing
- WCM70014 - Body
- WCM70015 - Spring Body Plate
- WCM70016 - Spring Plate
- WCM70017 - Spring Tube
- WCM70018 - Spring End Cap
- WCM70019 - Spring Cartridge Stud
- WCM70020 - Spring Set Screw
- WCM70021 - Spring Stop Washer
- WCM70022 - Spring Preload Seat
- WCM70023 - Spring Preload Stud
- WCM70024 - Spring-100
- WCM70025 - Spring Preload Barrel
- WCM70026 - Spring Spacer Tube
- WCM70027 - Name Plate

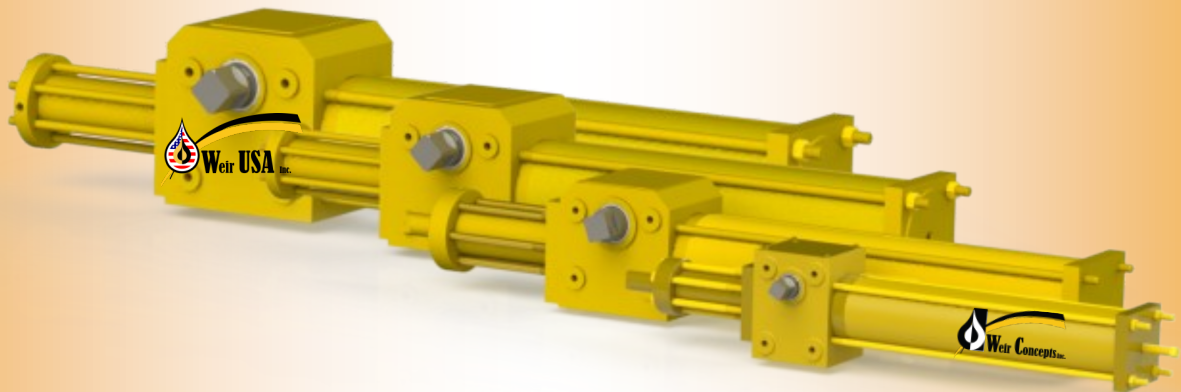

*Note: WCSCHP - Weir Self Contained High Pressure Pump

WCM Hydraulic Actuator Series: 35 / 50 / 60 / 70

PRODUCT GUIDE

WEIR WCM HYDRAULIC ACTUATOR SERIES: WCM 35/50/60/70



DISPLAYED here with our Weir Self Contained High Pressure Pump (WCSCHP)

Technical Library

www.weirusa.com

SCAN ME

SOLUTIONS FOR YOUR COMPANY NEEDS - **WORLD WIDE SHIPPING**



- HELP DESK -

FOR YOUR SUPPORT AND SERVICE

24 hours a day, 7 days a week

NO CHARGE ON CALLS SERVICE

We offer technical assistance, product knowledge, and reliable trouble shooting

Brochures/Maintenance info available online www.weirusa.com

Head Office:

7596 Wagner RD NW

Edmonton, Alberta CANADA T6E 5B2

info@weirusa.com / www.weirusa.com

1.866.462.1910 Toll Free

780.462.1910 ph | 780.462.1959 fax