



# PRODUCT GUIDE

## - WCM7970 HIGH-LOW PRESSURE PILOT -



**EXPECT QUALITY AND RELIABILITY**

**using our brand name WCM7970 HIGH-LOW PRESSURE PILOT**

Version 3.0

**Head Office:**



7596 Wagner RD NW  
Edmonton , Alberta CANADA T6E 5B2  
[info@weirusa.com](mailto:info@weirusa.com) / [www.weirusa.com](http://www.weirusa.com)

1.866.462.1910 Toll Free  
780.462.1910 ph | 780.462.1959 fax



# Weir USA Inc.

**DOMESTIC PRODUCTS MADE IN NORTH AMERICA**

**Details are the difference between ordinary and EXCELLENCE**

## 10-10,000 PSI Range

The WC7970 has a multi-piston arrangement which allows for full pressure range to be achieved without buying extra parts.

When used within standard safety systems, a pressure sensor monitors a specific media or process pressure source for changes to the normal operating range. Loss of pressure within the control circuit will begin a shutdown sequence or trigger an alarm, and pressure sensors can also indirectly operate on/off flow control valves or pneumatic drive pumps.

## Set Rising or Falling

By switching the inlet and vent lines you can change the action of the sensor to trip at increasing or decreasing pressure.

WC7970 is a two position, three-way pilot with universal ports (H, O, L) automatic reset (spring return) and pressure balance spool.

## Easy Mount

Choice of panel, wall or actuator mounting brackets available.

WC7970 is a self-contained unit comprised of the necessary components for four difference piston arrangements. Change over instructions and drawings are included in this manual. Parts which are not installed in your current piston arrangement are kept in an enclosed storage tube.

## Dual Action Hi/Low Configuration

A dual acting switch can be achieved by adding an additional WCM7970

## SST Construction

The WC7970 is NACE compliant.

**Solutions for your  
company needs**

# Weir USA at work for you

## OPERATION

The WC7970 pressure switch is used in conjunction with process control instruments and/ or Emergency Shutdown (ESD) valves. Upon reaching a predetermined set pressure, sensed through the 1/2" NPT Male connection of the assembly, the WC7970 will divert the stream of gas, oil or air from the target to vent. This creates a fail safe or alarm condition.

Supply pressure is connected to either the high port for rising pressure or the low port for falling pressure. The port not in use becomes the vent port. **All ports are labeled.**

**Weir offers technical consulting with total  
end-to-end solutions.**

## INSTALLATION

The WC7970 can be mounted in any position.

Two lock nuts can be supplied for panel mounting.

Machined within the piston housing of the WC7970 is a convenient 1/8"-27 NPT Female process connection and 1/2" NPT Male process connection.

**Only persons qualified through training or experience  
should install, operate and service this equipment.**

## DOMESTIC PRODUCTS MADE IN NORTH AMERICA

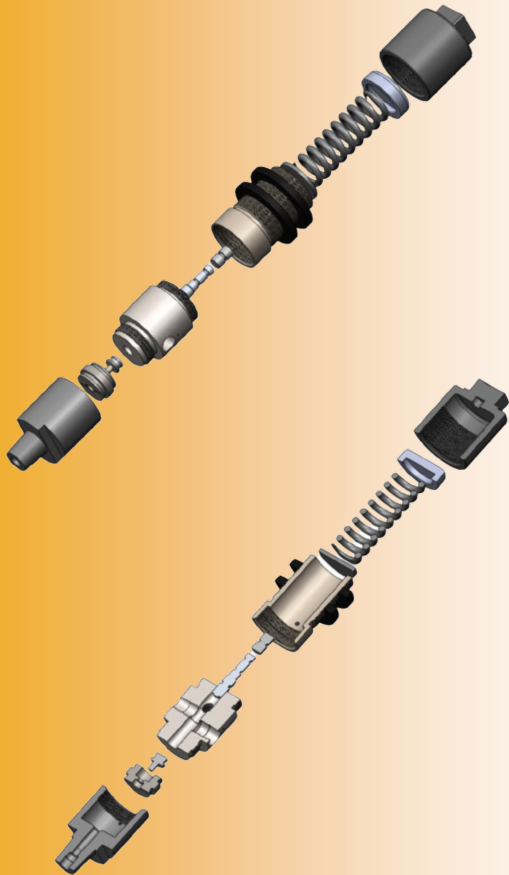

## Weir USA at work for you

Figure 1

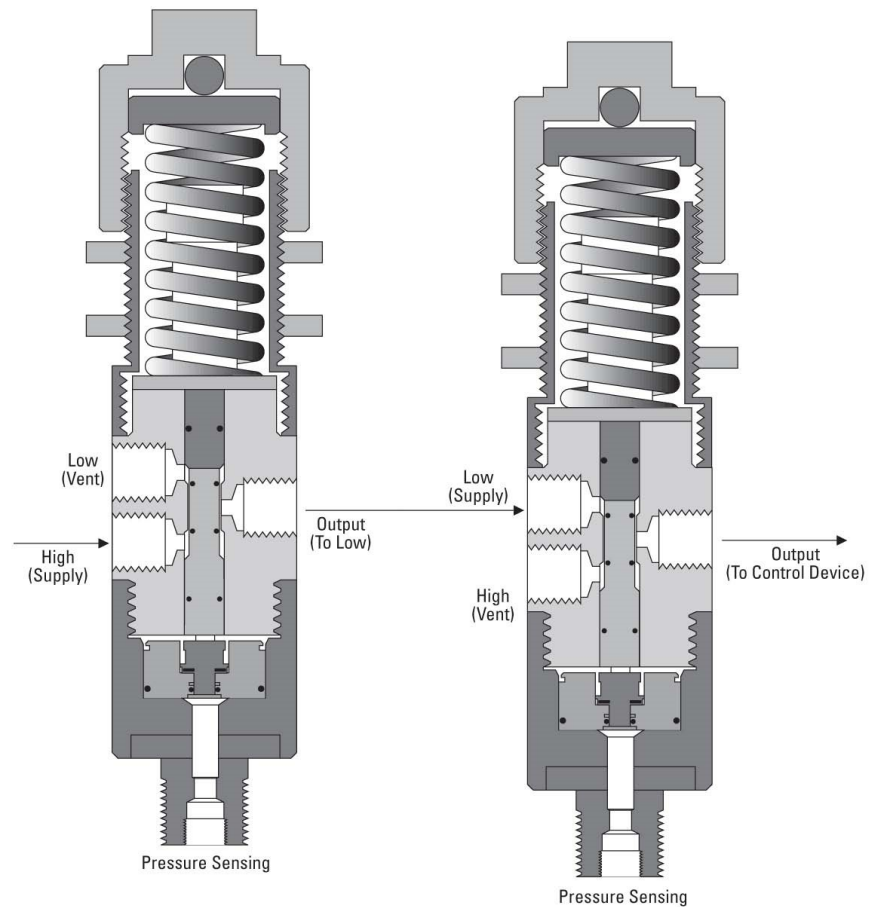

Table 1: WCM7970 Specifications

Characteristics		Dimensions
Dimensions		1.750" diameter x 8.0" length
Working	Process Pressure Inlet	10,000 psi maximum (689.5 bar)
	Control Ports	125 psi maximum (8.62 bar)
Connections	Process Pressure Inlet	1/2" - 14 NPT M and 1/8" - 27 NPT F
	Control Ports	1/4" - 18 NPT F
Weight		3.5 lbs. / 1.6 kg
Panel Hole Cutout Size		1 5/8" (39.81mm)

M=Male, F=Female

**Solutions for your  
company needs**

## PISTON ARRANGEMENT CHANGE OVER INSTRUCTIONS

The information in this brochure, including the parts listings and piston detail drawings, will assist you in completing the Piston Arrangement Change over.

**CAUTION: Always consult and follow established safety procedures of your facility prior to beginning disassembly of any Weir product. Ensure that all pressure is exhausted from the system prior to performing any service work. Failure to remove the pressure from the system can result in serious personal injury.**

1. Isolate and depressurize the control system.
2. Disconnect the control circuit instrumentation tubing from control valve, as well as the monitoring process connection from the piston housing.
3. Where possible, remove the WC7970 from the service location to perform the change over in a clean work environment.
4. Loosen the locknut and remove from the adjusting cap.
5. Gently relieve all spring tension by fully unscrewing the adjusting cap allowing access to the storage tube.
6. Unscrew piston housing from the valve body.
7. Turn the piston housing upside down and tap it gently on a flat, clean surface to remove the piston arrangement. The pistons should slide out easily.
8. Thoroughly clean the piston components, including the piston housing and internal bores, using warm water and a liquid detergent. Do not use abrasive tools or acidic cleansers. Dry all components with a cloth or a paper towel.
9. Lightly lubricate all components and seals, and assemble the piston arrangement as desired according to the enclosed detail drawing.
10. When inserting the new piston arrangement into the piston housing, apply even pressure. Press evenly using both thumbs on the piston's outer edges for the insertion of the 1-1/8", 1/2", and 3/16" piston arrangements.
11. For the 1/4" piston insertion, install the 1/4" piston first, using a needle-nosed pliers. Press the other piston components into place.
12. Lightly lubricate the threads of the piston housing, body and spring housing using a grease or substance appropriate for stainless steel.
13. Reassemble the pressure pilot.
14. Adjust the pressure setting to the required amount, and function test and pressure pilot. When the desired setting is achieved, tighten the lock nut securely against the adjusting cap.
15. Connect the instrumentation tubing and the pressure connection to the monitored process.
16. Introduce pressure to the pressure pilot's control circuit and monitored process inlet.
17. Resume normal operation.



## PISTON ARRANGEMENT CHANGE OVER INSTRUCTIONS - Cont'd

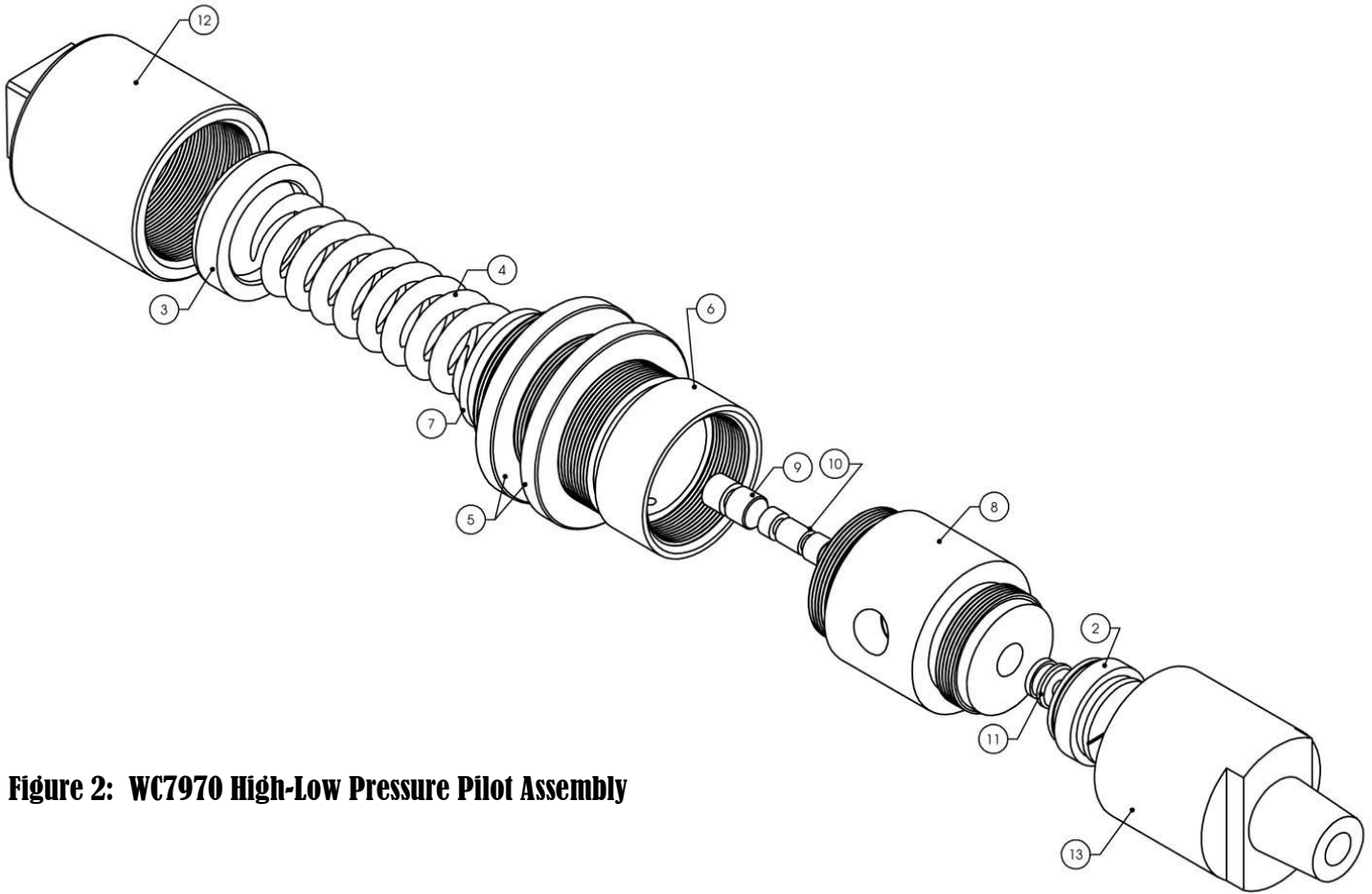

**Figure 2: WC7970 High-Low Pressure Pilot Assembly**

No.	Part Number	Name
1	WC7970-21	1/4" Piston
2	WC7970-13	Large Piston
3	WC7970-03	Spring Guide
4	WC7970-04	Spring
5	WC7970-05	Locknut
6	WC7970-06	Spring Housing
7	WC7970-07	Stop Plate
8	WC7970-08	Body Housing
9	WC7970-09	Upper Stem
10	WC7970-10	Lower Stem
11	WC7970-11	Small Piston
12	WC7970-12	Adjusting Cap
13	WC7970-15	Piston Housing

**Solutions for your  
company needs**

**PISTON ARRANGEMENT CHANGE OVER  
INSTRUCTIONS - Cont'd**

Key	Part Number	Qty.	Description	Material
11	WCM7970-11	1	Small Piston	316 Stainless
13	WCM7970-13	1	Large Piston	316 Stainless
14	797014	1	Snap Ring	304 Stainless
18	V-75-119	1	Seal	Parker HSN
19	TFE-008	1	Back-up Ring	Teflon
20	V-75-008	1	Seal	Parker HSN

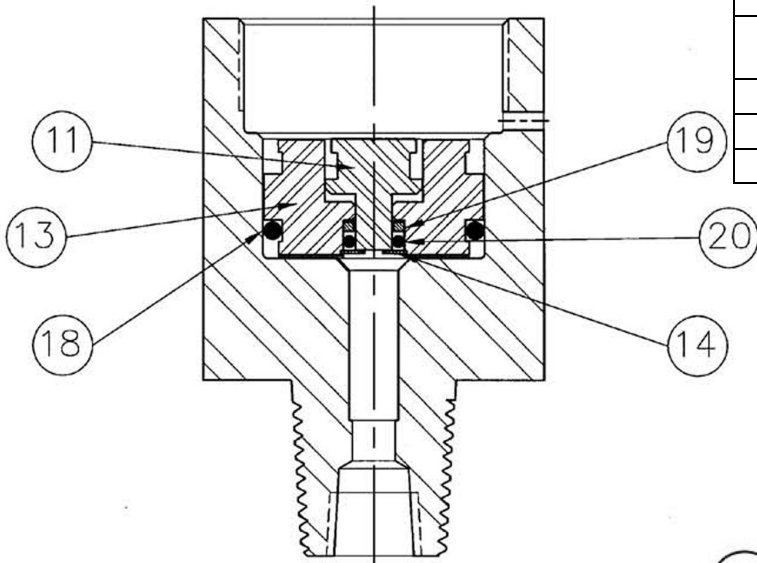

**Figure 3: 3/16 Piston Arrangement Enlarged Detail Drawing**

For pressures from 40679-68947 KPA

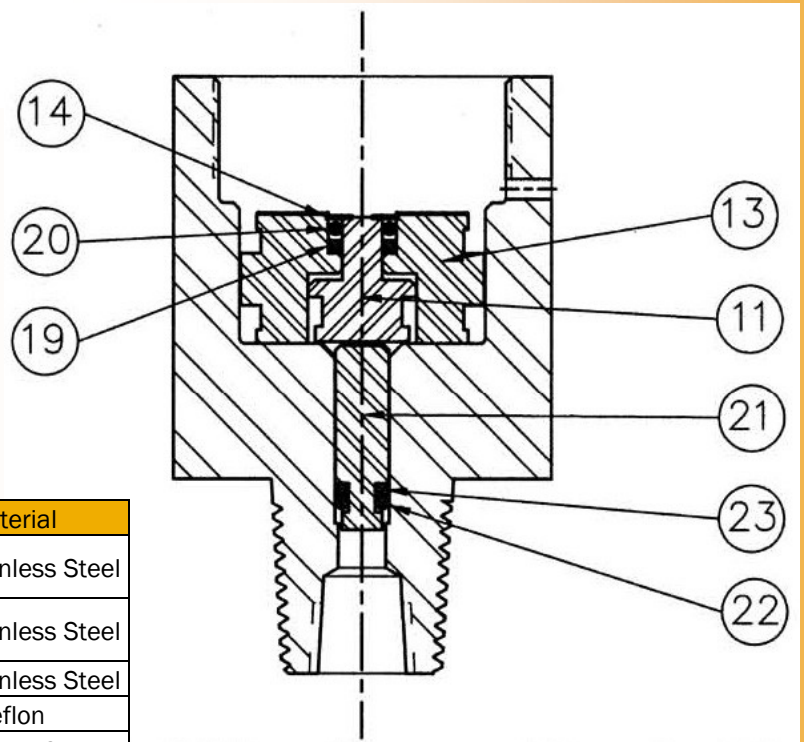

**Figure 4: Piston Arrangement Enlarged Detail Drawing**

For pressures from 9928-40679 KPA

Key	Part Number	Qty.	Description	Material
11	WCM7970-11	1	Small Piston	316 Stainless Steel
13	WCM7970-13	1	Large Piston	316 Stainless Steel
14	797014	1	Snap Ring	304 Stainless Steel
19	TFE-008	1	Back-up Ring	Teflon
20	V-75-008	1	Seal	Parker HSN
21	WCM7970-21	1	1/4" Piston	316 Stainless Steel
22	V-75-006	1	Seal	Parker HSN
23	TFE-006	1	Back-up Ring	Teflon

**Solutions for your  
company needs**

**DOMESTIC PRODUCTS  
MADE IN  
NORTH AMERICA**



## PISTON ARRANGEMENT CHANGE OVER INSTRUCTIONS - Cont'd

Key	Part Number	Qty.	Description	Material
11	WCM7970-11	1	Small Piston	316 Stainless Steel
13	WCM7970-13	1	Large Piston	316 Stainless Steel
18	V-75-119	1	Seal	Parker HSN
24	TFE-012	1	Back-up Ring	Teflon
25	V-75-012	1	Seal	Parker HSN

**Figure 5: 1/2" Piston Arrangement Enlarged Detail Drawing**

For pressures from 2000-9928 KPA

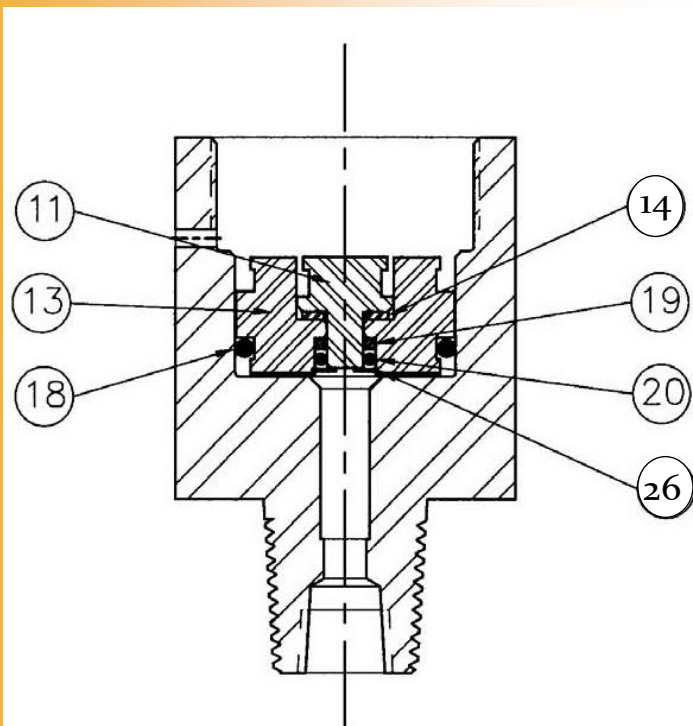
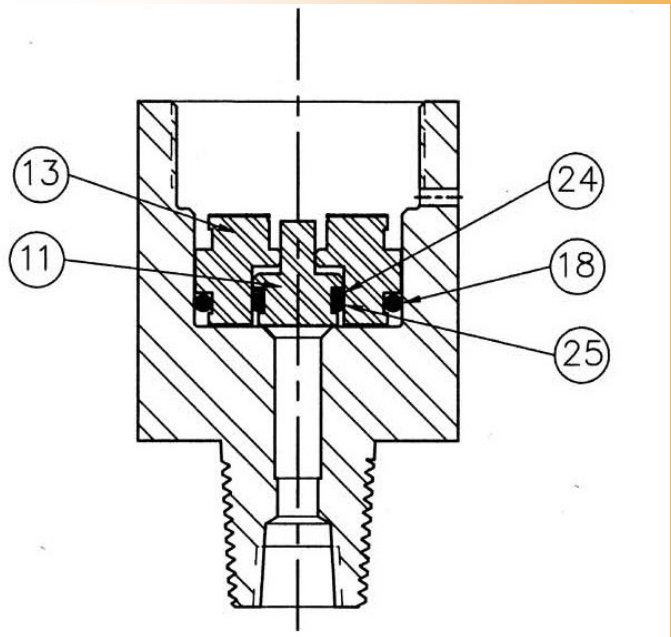

**Figure 6: 1-1/8" Piston Arrangement Enlarged Detail Drawing**

For pressures from 70-2000 KPA

Key	Part Number	Qty.	Description	Material
11	WCM7970-11	1	Small Piston	316 Stainless Steel
14	WCM7970-14	1	Stop Washer	316 Stainless Steel
13	WCM7970-13	1	Large Piston	316 Stainless Steel
26	797014	1	Snap Ring	304 Stainless Steel
18	V-75-119	1	Seal	Parker HSN
19	TFE-008	1	Backup Ring	Teflon
20	V-75-008	1	Seal	Parker HSN

**Solutions for your  
company needs**

## WCM7970 HIGH-LOW PRESSURE PILOT - ADJUSTMENT 2--15 PSI - ASSEMBLY

Figure 7

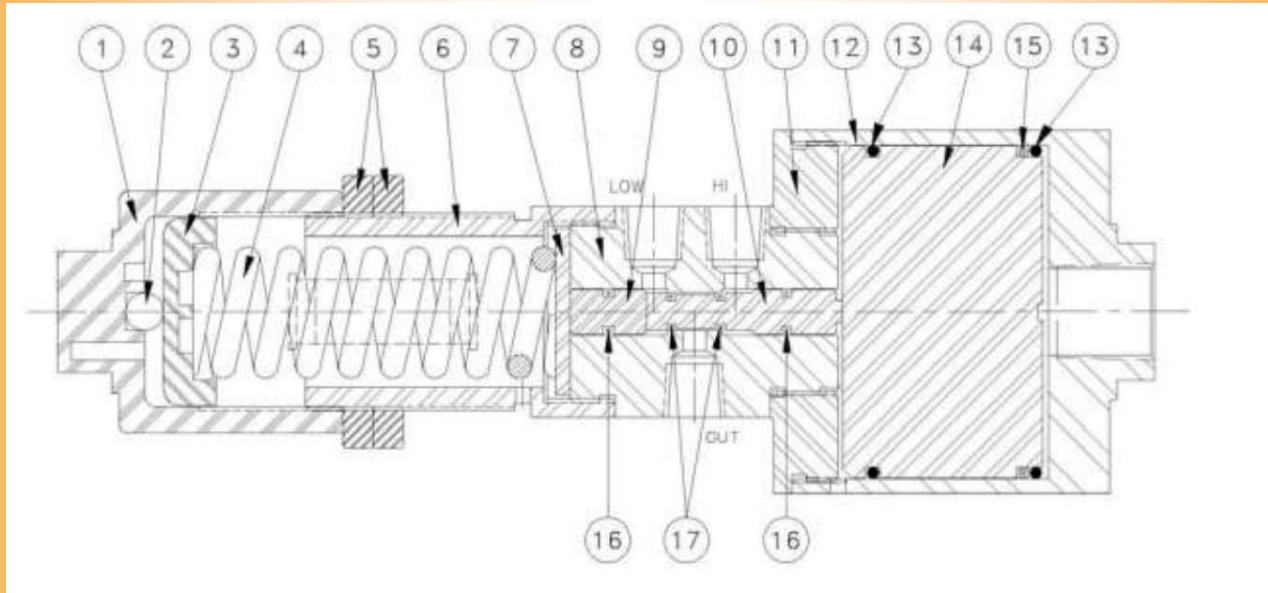

Item Number	Part Number	Qty.	Description
1	WCM7910	1	Adjusting Cap, Black Delrin
2	WCM7920	1	6/16" Ball Bearing, SST
3	WCM7930	1	Spring Guide, Black Delrin
4	WCM7940	1	Spring, 302 Stainless Steel
5	WCM7950	2	Lock Nut, Black Delrin
6	WCM7960	1	Spring Housing, 316SST
7	WCM7970	1	Stop Plate, 316 SST
8	WCM7980	1	Body Housing, 316SST
9	WCM7990	1	Upper Stem, 316SST
10	WCM79110	1	Lower Stem, 316SST
11	WCM79111	1	Adapter, Low Pressure, 316SST
12	WCM79112	1	Piston Housing, 316SST
13	WCM79113	2	O-ring, Viton Coated TFE
14	WCM79114	1	Piston, LP, 316SST
15	WCM79115	1	Wiper Ring, Viton
16	WCM79116	2	Seal, Viton Coated TFE
17	WCM79117	2	Seal, Viton Coated TFE

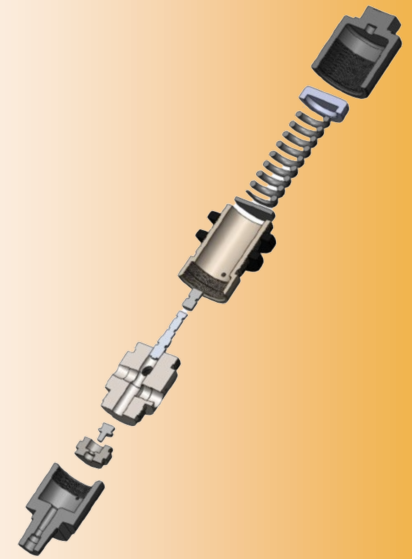

**DOMESTIC PRODUCTS  
MADE IN  
NORTH AMERICA**

**Solutions for your  
company needs**





# PRODUCT GUIDE

## WEIR WCM7970 HIGH-LOW PRESSURE PILOT



Technical Library



[www.weirusa.com](http://www.weirusa.com)

SCAN ME 

**We provide superior service, quality products and your company solutions.**

## SOLUTIONS FOR YOUR COMPANY NEEDS - **WORLD WIDE SHIPPING**



**Weir USA Inc.**

**- HELP DESK -**

FOR YOUR SUPPORT AND SERVICE

**24 hours a day, 7 days a week**

**NO CHARGE ON CALLS SERVICE**

We offer technical assistance, product knowledge, and reliable trouble shooting

Brochures/Maintenance info available online [www.weirusa.com](http://www.weirusa.com)



**Head Office:**

7596 Wagner RD NW

Edmonton, Alberta CANADA T6E 5B2

[info@weirusa.com](mailto:info@weirusa.com) / [www.weirusa.com](http://www.weirusa.com)

1.866.462.1910 Toll Free

780.462.1910 ph | 780.462.1959 fax